

Its two different finishes in *Red/Black* and *Black/Black* will make it easy to integrate perfectly in your trendy home design.

Its structure in powder coated steel can welcome a very comprehensive AV system with a perfect stability.

Its height has been optimized to insure the best comfort with screens up to 50".

The shelves in black lacquered glass give this very versatile piece of furniture an elegant and contemporary touch.



SPECIFICATIONS

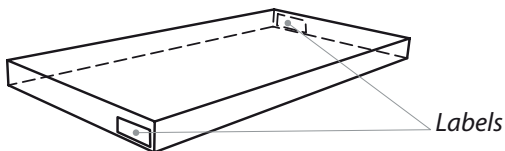
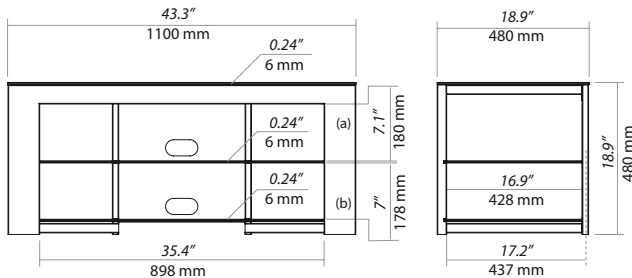
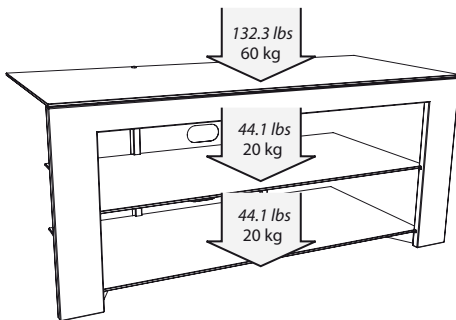

DESIGN

Finishes: *Red/Black, Black/Black*

Structure: Powder coated steel feet (red or black) and framework

Shelves: Black tempered glass

Miscellaneous: Cable management system

MAXIMUM LOAD

Upper shelf: 132.3 lbs / 60 kg

Internal shelves: 44.1 lbs / 20 kg

USABLE DIMENSIONS

Overall dimensions (W x H x D):

43.3" x 18.9" x 18.9" / 1100 x 480 x 480 mm

Upper shelf (W x D): 43.3" x 18.9" / 1100 x 480 mm

Internal shelves (W x D): 35.4" x 17.2" / 898 x 437 mm

Height between shelves: (a) 7.1" / 180 mm
(b) 7" / 178 mm

PACKAGING

Delivered disassembled with screws kit, mounting instructions and tools

Quantity/box: 1

Type: Brown cardboard

Dimensions (W x H x D):

47.2" x 4.9" x 22" / 1200 x 125 x 560 mm

Gross weight: 69 lbs / 31,3 kg

Net weight: 60.6 lbs / 27,5 kg